

## QUICK START :

1. Connect the safety valve at the inlet of water heater if supplied separately. Don't install water heater without safety valve.
2. Hook the water heater on wall with the help of mounting brackets. Take Necessary dimensions for making holes for mounting brackets.
3. Connect the inlet & outlet piping as marked on water heater.
4. Start water flow inside Water heater & fill it completely till water comes out from outlet connection.
5. Connect the electrical cord to power point.
6. Switch on the water heater's main supply, red indicator lamp comes on.
7. The red indicator lamp switches off indicates water inside the water heater reached to the set temperature
8. Run a complete cycle of Thermostat ON to Thermostat cut OFF, in presence of service provider / Installation technician / plumber.

**Racold**

Reborn Everyday With Hot Water

## ORIGINAL INSTRUCTIONS

## INSTRUCTION MANUAL

Andris R  
Andris UNO  
Andris Lux Plus  
Andris Slim

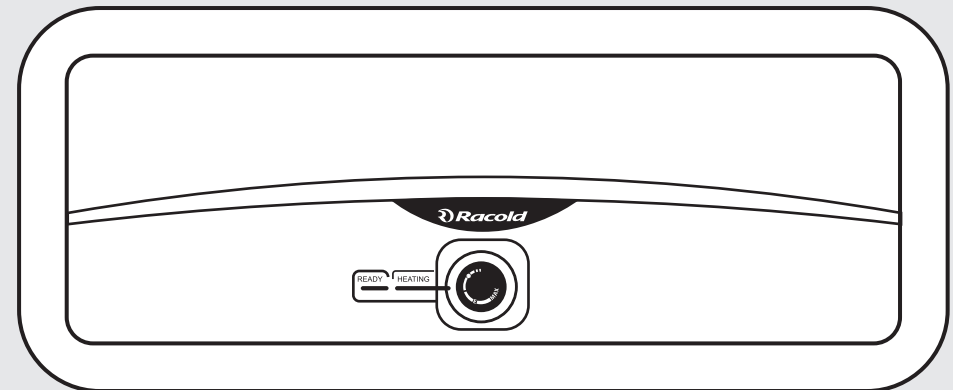
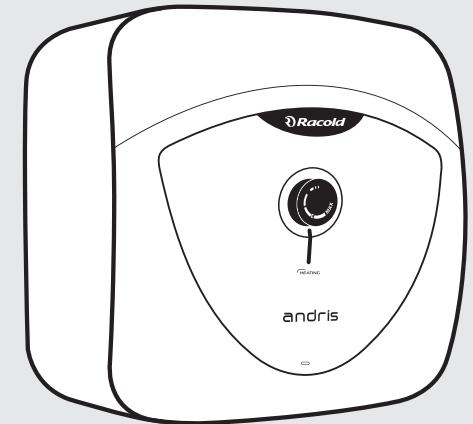

### Ariston Group India Private Limited

1<sup>st</sup> Floor, Office No. 103, Mayfair Tower, Wakdewadi, Shivajinagar Pune - 411005,  
Maharashtra, India.

Customer care number:  
020 6734 2288, +91 8600 25 6000 | 7362 888 999 

Email: [customer.care@racold.com](mailto:customer.care@racold.com)

Dear Customer,

Thank you for choosing a world-class product from Ariston Group India Private Limited. Your choice for nothing but the best is reflected by your trust placed in Ariston.

Racold is registered trademark of Ariston Spa, Italy.

Ariston Group India Private Limited is a fully owned subsidiary of Ariston Spa, Italy and part of the Ariston Group the leaders in water heater.

Today Ariston Group India Private Limited is the largest provider of water heating solutions in India, catering to all sectors water heating namely "Electrical, Gas, Solar and Heat Pump water heaters"

The Racold range of products from Ariston Group India Private Limited have changed the industry standards by setting new benchmarks in quality, aesthetics and performance.

Our many firsts in India include:

- Water heater with rust proof polypropylene body.
- Stainless steel inner container with multi-function safety valve for high Pressure operation without additional pressure reducing valve.
- PUF insulation for maximum energy saving.
- Energy labeling for any domestic electrical appliances
- Only water heater with quality and performance certification as per IEC/EN and Indian standards (ISI mark).
- Won highest number of National Energy Conservation Award from BEE (Bureau of Energy Efficiency) for electric storage water heaters.

Retain this manual safely and in case you need any assistance you may get in touch with any of our customer care centres, the details of which are enclosed.

Kindly follow the instructions given in this manual and enjoy years of trouble free performance.

**ARISTON GROUP INDIA PRIVATE LIMITED**

## REBORN EVERYDAY WITH HOT WATER

Electric | Solar | Gas | Heat Pump



[www.racold.com](http://www.racold.com)





Please complete the following details:

Product: ELECTRIC STORAGE WATER HEATER

Model No: \_\_\_\_\_

Serial No: \_\_\_\_\_

Purchaser's Name & Address: \_\_\_\_\_

Dealer's Name & Address: \_\_\_\_\_

Dealer's Signature : \_\_\_\_\_

Cash Memo No: \_\_\_\_\_

Date of Purchase: \_\_\_\_\_

The Racold water heater comes with warranty for a period of two years from the date of purchase against electrical or mechanical failure caused through defective material and workmanship. The inner container warranty against leakage is for 7 years and the heating element warranty is for 3 years. In event of failure covered by this warranty, you are requested to contact our customer care & obtain the complaint number. Our trained technicians will repair the product at our option. No further liability for the consequential or damage is accepted or implied. We will not be responsible for any human injury, property damages consequential damages caused due to improper use. All disputes will be subjected to Pune Jurisdiction only. The warranty on the tank includes the tank only. It does not include any other parts inside or outside of the tank.

- 1) Annual check of anode is done mandatorily and its replacement done in case of consumption (rod diameter less than 7 mm)
- 2) Warranty will be no more valid in case the maintenance of anode is not done as per point no 1.



**Following things shall not be covered under warranty:**

- 1) Any plumbing and/or Electrical related problems, not related to product.
- 2) Any defects arising due to wrong and/or non recommended installation procedure.
- 3) Dry heating of water heater.
- 4) Consumables such as anode.
- 5) Any human injury, property damages and consequential damages caused due to improper use.

**PRODUCT FEATURES:**

1. High density PUF insulation.
2. Strong non-corrosive and durable PP outerbody and inspection cover.
3. Hi-tech thermostat and cutout, for double safety.
4. Titanium Plus Enameled & durable inner container with high pressure withstanding capacity enabling long life & suitable for high rise buildings and pressure pump applications.
5. 4 in 1 Multifunction Safety Valve.
6. Compact size.
7. Drip proof construction.
8. Special flushmounting.
9. **Flexomix:**  
During the use, every withdrawal of hot water from the water heater is then balanced by cold water coming in. The "Flexomix" technology provides better management of the cold water coming inside the water heater. The special flexomix deflector allows the water to

mix more slowly, keeping the internal water temperature high and avoiding re-heating of water unnecessarily thereby saving precious electricity. The flexomix system, with its new deflectors of water coming in, allows the user to draw upto 10% more hot water than a traditional water heater of the same capacity.

**10. Ag + active:**

The Ag+ cartridge technology by Racold have the added advantage of an antibacterial capability, and actively stop the proliferation of E-coli, Salmonella, Legionella, Mould Fungi & more. Silver spheres placed inside the tank in a specifically designed cartridge, at the level of the water inlet pipe, allowing the water contained in the tank to receive bacteriostatic effect by contact with Ag+ spheres. This is available in Andris Lux Plus models only.

**Andris Slim**

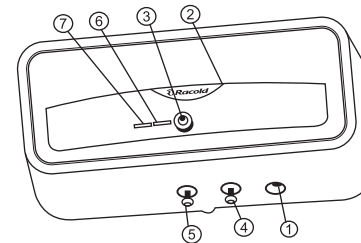

**KNOW YOUR WATER HEATER:**

- 1) Drainage cap
- 2) Front cover
- 3) Temp control knob (clockwise incremental)
- 4) Inlet pipe
- 5) Outlet pipe
- 6) Red lamp
- 7) Blue lamp

**Andris Lux Plus**

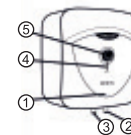

**Andris Uno/R**

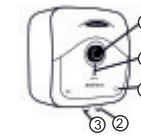

- 1) Front Cover
- 2) Inlet pipe
- 3) Outlet pipe
- 4) Red lamo
- 5) Temp control knob (clockwise incremental)

## IMPORTANT INSTRUCTIONS:

Ariston Thermo India Pvt Ltd. cannot be held responsible for the damages caused by wrong installation, faulty material, using substandard water or for not following instructions included in this instruction manual, particularly:

1. Installation of the water heater should be done by qualified personnel only.
2. In case the installation is being done on a wall with hollow bricks, refer 'Preparation for Installation' Page 6.
3. Use pressure reducing valve incase rated water pressure is higher than recommended.
4. The electrical connection should be in accordance with the instruction given, refer Page 7.
5. The safety valve supplied with the water heater should be fitted to the inlet connection and should not be disturbed with. For servicing safety valve, refer 'Safety Devices' Page 4.
6. When newly installed, make sure that the water flows freely from the outlet tap (or spout) before electric supply is switched on.
7. Inlet when water line should be continuously open when water heater is in use expect when it is being serviced.
8. Switch off water heater when not in use to save electricity charges.
9. In case a dead weight safety valve is being used it should be serviced regularly.
10. It is recommended that the IN/OUT pipes and heating element be de-scaled at least once in a 6 months.
11. While using the water heater first time, ensure water is dispensed through outlet before switching ON product .Failure to do so will cause damage to heating element.
12. As per safety norms, Thermostat & Cut out are set at desired temperature & its recommended not to change the setting.
13. As per safety norms, Safety Valve is set at desired Pressure & its recommended not to change the setting.
14. Optimum performance of the water heater is achieved when total hardness of water <400 ppm & chloride content <300 ppm.

## PRECAUTIONS:

1. In order to avoid a hazard due to inadvertent resetting of the thermal cutout, this appliance must not be supplied through an external switching device, such as a timer ,or connected to a circuit that is regularly switched on and off by the utility .
2. Incase a pressure reducing valve (or a non-return valve) is used in the installation, please ensure that it is installed at a minimum distance of 12 feet from the inlet point. Installing the PRV (or NRV) without respecting this minimum distance may cause safety valve dripping.
3. The new hose-sets to be used and that old hose-set should not be reused.
4. This appliance can be used by children aged from 8 years and above and persons with reduced physical, sensory or mental capabilities or lack of experience and knowledge if they have been given supervision or instruction concerning use of the appliance. Cleaning and user maintenance shall not be made by children without supervision.
5. If the supply cord is damaged, it must be replaces by a special cord or assembly available from manufacturer or its service agent having same electrical rating and specification.
6. Please use a 3 pin plug of 16 A rating for electric connection & ensure secure connection of the earthing wire.
7. Please ensure to mount the water heater keeping sufficient space on the left hand side (~350- 400 mm). This will facilitate easy servicing product without dismounting.  
Maintenance Then anode should be checked within 12-18 months from the installation. If the diameter goes below 7 mm, it should be replaced with a new anode (this operation should be performed by authorized personnel)

## IMPORTANT

This warranty is valid subject to installation of the unit as per the instruction manual and the conditions stated there in. This warranty will not apply to any Racold Water Heater which has been tampered with or altered in any way or which has been subjected to misuse, negligence or accident.

For water heaters installed at inaccessible places such as above a false ceiling, inside a duct etc. It is the responsibility of the customer to dismount the product and make it available to the service representative.

Its recommended to take AMC & Extended warranty from Racold's authorized service franchisee.

We recommend to use genuine Racold spare parts only.

Visit charges shall be applicable for product installation, demonstration & explanation related calls.

## WARNING MARKING

The instruction shall include a warning that the appliance shall be disconnected from its power source during service and when replacing parts and, if that the removal of the plug is foreseen, it shall be clearly indicated that the removal of the plug has to be such that an operator can check from any of the points to which he has access that the plug remains removed."

## CAUTION MARKING

In order to avoid a hazard due to inadvertent resetting of the thermal cut-out , this appliance must not be supplied through an external switching device , such as a timer , or connected to a circuit that is regularly switched on and off by the utility . "

### Correct Disposal of this product



This marking Indicated that this product should not be disposed with other household wastes throughout the EU. to prevent harm to the environment or human health from uncontrolled waste disposal , recycle it responsibly to promote the sustainable reuse of material resources . To return your used your device, Please use the return and collection systems or contact the retailer where the product was purchased. They can take this product for environmental safe recycling.

## Electric Water Heater Installation Guidelines for Plumbers

### इलेक्ट्रिक वॉटर हिटर का इन्स्टॉलेशन प्लंबर के लिए जानकारी

- Read instruction manual carefully and follow installation instructions.
- Safety valves are pre-set for certain working pressure. Under any circumstances do not tamper/over-tighten the safety valve.
- Continuous water dripping from Safety valve is an indication of excessive pressure at inlet of water heater compared to the rated pressure. In that case install pressure reducing valve at the inlet.
- Check for leakages after installation, plumbing & before switching ON the power supply.
- Ensure flow of water from outlet before connecting electric power supply to the appliance.
- Do not use excessive force while tightening inlet and outlet Coupling. This may cause serious damage to the Water Heater. Use Cross spanner for tightening.
- Check supply voltage at the place of installation 230 V.
- Ensure proper earthing of electrical connection.
- No extension cords to be used.
- Use only ISI marked electrical accessories of proper rating e.g. 3 Pin Plug, Connection Boxes, Wires etc.
- In storage water Heaters, check whether red lamp is glowing when the water heater is switched on.
- Ensure all Couplings/Joints are leak-proof
- Check the Water Heater operation for one complete cycle i.g. one cycle of Thermostat operation i.g Cut-off and cut- in

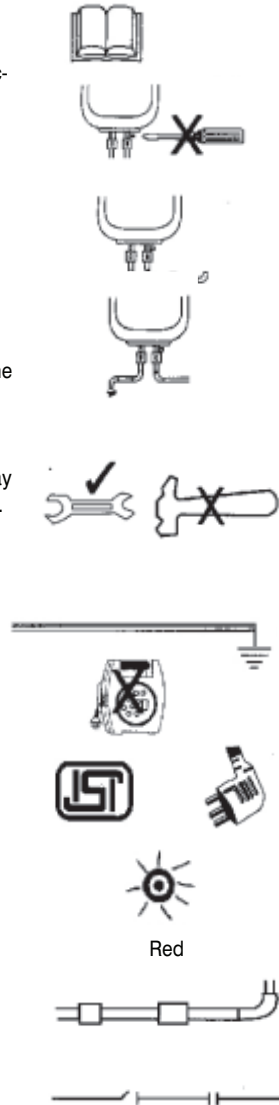

## SAFETY DEVICES:

**A- Multi functional safety valve: (Non-Return Valve/Vacuum Release valve / Pressure Release valve / Drain valve)** Non - return function will not allow the back flow of hot water from inlet. In-built multifunction safety valve (Pressure relief valve) is set to operate between 7.5 bar (109 p.s.i.)

Vacuum relief valve prevents the formation of vacuum inside the container. Drain lever (L) is provided to drain the water heater only in case of servicing. Check for any leakage before switching on electric supply. In case of safety- valve dripping during normal use, connect a discharge pipe (P) (as shown) for piping away the

relieved water. In a continuously downward direction and in a frost-free environment. **In case copper Pipe plumbing is done, additional ½ inch connector or adaptor to be connected to avoid safety valve damage by copper pipe.**

Contact nearest service centre for discharge pipe availability.

To avoid deposition of limes in the safety valve, please move the lever (L) up & down few times. This should be done at least once in a month. Minimum water of 50 cms. is required at inlet for water to enter inside the container.

**The safety valve (A)** Should be serviced atleast once a month. Before servicing the safety valve, ensure that the water heater is switched off and water inside is not hot Connect the discharge pipe (P) in a downward sloping position to the safety valve at the discharge hole provided. The water may drip from the discharge pipe of the pressure relief device and that this pipe must be left open to the atmosphere. A discharge pipe connected to the pressure – relief device is to be installed in a continuously downward direction and in a frost-free environment.”



Fig. 2

**B. Thermostat:**

Hi-tech adjustable thermostat with automatic ON-OFF indication on display of control panel and variable setting of temperature. The temperature of water at which the thermostat.

Will cut off can be adjusted by setting the control panel to the desired temperature .This should be kept as low as possible, consistent with hot water demand. Scale formation in water heaters can be limited if due care is given to the temperature. The thermostat (NTC) can be withdrawn without having to drain the water and in the installed position.

**C. Thermal Cutout:**

Hi-tech thermal cutout non-self resetting type set to disconnect electrical supply through two poles for extra safety. Please contact qualified service personnel in such an event.

## HEATING ELEMENT:

**Self cleaning heating element:**

The heating element is made of best anti-corrosive material & guarantees absolute isolation between electricity & water.

Racold's self-cleaning Heating Element made of a special stainless steel alloy that has a specially

treated surface (brightened).The self cleaning Heater Element has proved to be an extra help for Low energy consumption & for a longer life of the inner tank. Thanks to its smooth & bright surface, the lime stone done lay on the heating element thus allowing the heat to be efficiently exchanged with the water, even after long period use.

### OPERATION INSTRUCTIONS:

1. Switch on the water heater's main supply, red indicator lamp comes on.
2. The red indicator lamp switches off indicates water inside the water heater reached to the set temperature.
3. The red indicator lamp, which is ON during the normal operation, goes OFF when the thermal cut-out is activated. Contact qualified service personnel in this event.

### SPECIFICATIONS:

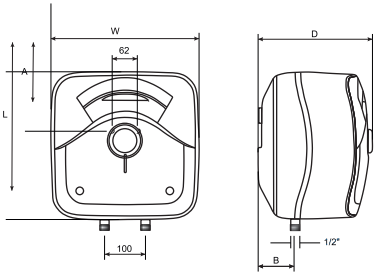

Sr. No.	Models	L/W	D	A	B
1	AN 15 LUX 2KW	360	346	144	78
2	AN 25 LUX 2KW	447	410	165	114
3	AN 10 LUX PLUS 2KW	360	298	144	90
4	AN 15 LUX PLUS 2KW	360	346	144	78
5	AN 25 LUX PLUS 2KW	447	410	165	114
6	AN 10 R 2KW	360	278	144	90
7	AN 15 R 2KW	360	328	144	78
8	AN 25 R 2KW	447	390	165	114

**Maximum rated pressure-**  
7.5 Bar/750000 Pascal/0.75 MPa/75N/cm<sup>2</sup>  
/-80m water head

**Minimum inlet water pressure.**  
5000 Pascal (0.05 bar ) for all models

**IP rating - IP 23 for all models**

NOTE:  
a) All dimensions are in 'mm'  
b) 'A' represent the distance between top of product to mounting positions.  
(back side)

### DOs AND DON'Ts OF WATER HEATER:

#	DOs	Remarks
1	Installation of water heater should be done by qualified person only preferably from Racold service	Product warranty will get void in case of wrong installation
2	Use pressure reducing valve in case rated water pressure is higher than recommended.	To Avoid Water dripping from safety valve.
3	Inlet water line should be continuously Open when water heater is in use except when it is being serviced.	
4	Ensure proper leveling of the unit while doing installation	If tilted, it may affect the hot water out put quantity
5	Ensure proper earthing at the place of installation	Chances of getting Shock
6	Use ISI marked or Branded company Power Plugs only.	Use 16 Amp Power Plug only
7	Use of two spanners suggested while installing the product (Connecting the hose pipes)	There may be a chance of crack on the pipes if we don't do so
8	Ensure water coming out from outlet prior switching the unit ON (first time)	If no water inside tank, unit goes into dry heat causing damages, burning etc.
9	it is mandatory descale IN/OUT pipes, heating element and safety valve at least once in 6 months when water hardness is greater than 400 ppm, if lower (1) this type of maintenance is recommended. Operation must be done only by Racold authorized service (intervention charge shall be applicable)	This helps in Improving product life.
10	As per the safety norms Thermostat, Cut out are set at desired temperatures and safety Valve set at desired pressure and its recommended not to change the settings.	Product warranty will get void if setting changed.
11	Power OFF the unit while servicing the water heater unit.	Chances of product burning/safety purpose
12	Use only Genuine company spare parts from authorised service centers	Product warranty will get void if used other then company recommended spare parts.
#	DON'Ts	
1	Use connectors in case if is required to connect another cord with main power cord come along with the product.	Chances of product burning/safety purpose
2	Do not tamper the thermostat setting	As per safety standards, thermostats are set at desired temperatures. Recommend not to change the settings.
3	Do not switch ON the product without checking the water coming out from outlet	Chances of product burning
4	Do not adjust / disturb Safety valve setting	As per safety standards, Safety valve are set at desired pressure. Recommend not to change the settings.

### IMPORTANT NOTES:

1. Optimum performance of the water heater is achieved when the total hardness of  $\leq 400$  ppm & chlorides content  $\leq 300$  ppm.
2. In case a pressure reducing valve (or non return valve) is used in installation, please ensure that it is installed at a minimum distance of 12 feet from the inlet point.
3. Please ensure the installation of water heater to be done by keeping minimum 1 foot from the wall on either side.
4. Anode should be checked periodically within 6 months. If the anode goes below 7mm diameter, replace it by authorized service personnel only at chargeable basis.
5. In case of product installed at inaccessible place, it is responsibility of customer to dismount the product and make it available to the service representative.
6. AMC-it is recommended to take AMC and extended warranty from authorized service franchisee.
7. Visit charges shall be applicable for product installation, Demonstration & explanation related calls.
8. Please ensure proper ventilation whenever the unit is installed to avoid any rust formation/aggregation.

## TROUBLE SHOOTING GUIDE FOR WATER HEATER:

#	Problem/Observation	Possible causes	Solution/Remarks
1	Water Heating takes longer time specified in instruction manual	Scaling on the Heating Element cause slower water heating	Get the Heating element de-scaled from authorised service person or replace with genuine spare parts recommended by Company Measure the temperature of water using thermometer. Adjust the flow rate at 3 Ltrs/min
		Low voltage at certain places	Check the voltage at customer's place.
2	Equipment creates abnormal Noise	High voltage at fluctuations, Hard water	Recommend Spare HE with low watt density (8W/cm <sup>2</sup> )
	Equipment creates hissing Noise	Due to scalling on HE	Descaling HE
3	Unit not working	Power point may not be working	Need the line at customer's place to be checked
		Check for any short circuit of harness/ Power cord inside	
		Cut out operated due to dry heating	Reset Cut out
4	Leakage of the unit	Rusting of the tank	Check from where the leakage is (tank collar, gasket, HP), Replace or repair based on the observation
		Not enough torque to the bolts on HP/HE flange	Replace or repair based on the observation
5	No Hot water our put	Leaking from HE Brass flange (instant WH )	Replace HE
		HE not working	Reset Cut out
		Thermostat low setting (check if someone tempered the setting in instant water heater)	
		Cut out trip	
6	User gets mild shock when using WH	Inlet valve closed	Open the Inlet valve
		Improper earthing at customer's place	Check for proper earthing & if not then suggest customer to do it properly.
7	Outlet water blockage	Heavy scaling on Outlet pipe opening eng	Descaling the product from authorized service personel
8	Leaking from MFSV (Safety valve)	Excess pressure then rated pressure.	Check the pressure when unit is in ON condition, ensure inlet line is ON. <b>Note</b> When MFSV is dripping, it ensures safety of the equipment from excess pressure. Put drain pipe at MFSV with clip
		Check NRV position from inlet pipe	It should be minimum 12 feet from equipment
			Check if PRV is there in high rise building.
9	Water Heater unit burnt	Short circuit of the harness/Power Cord	Replace Harness asm or Power Cord
		Use of Low amp Power Cord	
10	Smell comes out of water	If Water heater unit is not used in 15 + days, water inside smells for some time.	Flush out 2 times capacity of water heater.

Model	ANDRIS			ANDRIS SLIM	
Capacity declared (Ltrs)	10L	15L	25L	15L	25L
Real capacity (Ltrs)	11.5	15.5	27.5	21.2	31.1
Power supply (kw)	230V, 50Hz, Single Phase				
Wattage (kw)	2	2	2	2.5	2.5
Reaheating Time for 50°C temp rise (minutes) Max	20	30	50	30	40
Mean not water output temp °C (Min)	60	60	60	60	60
Maixing factors (Max%)	10	10	10	20	20

### Installation Andris Slim 30L :

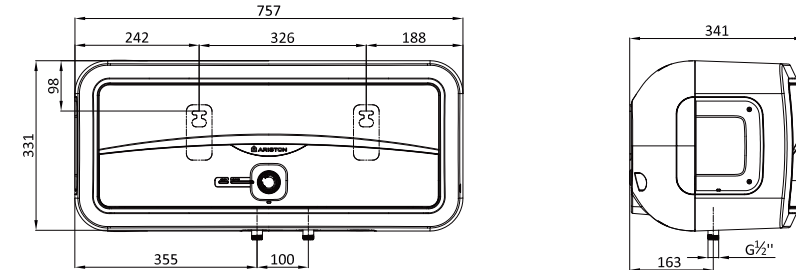

### Installation Andris Slim 20L :

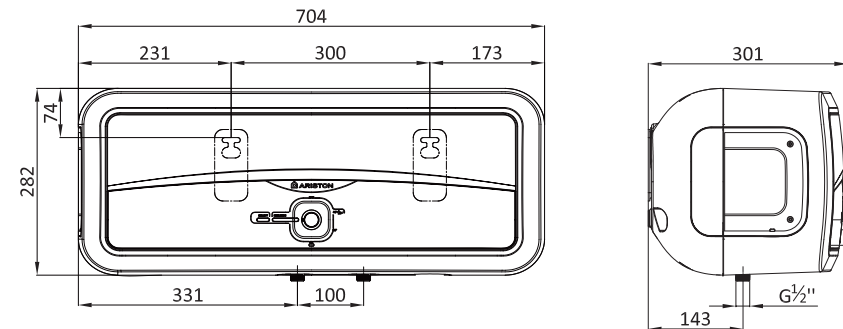

## PREPARATION FOR INSTALLATION:

1. For the installation of this water heater you need to prepare the wall suitably and more so if the wall is constructed out of hollow bricks.
2. For solid bricks the usual method of installation of drilling holes in the wall and securing bolts in the right position with the help of cement concrete can be adopted, use M8 ×75 mm bolts.
3. However for hollow bricks the following procedure should be adopted:
  - ⇒ Dig up sufficient space to accommodate the wall mounting bracket supplied with this water heater, upto a minimum depth of 80mm and fill up the complete space with cement concrete.
  - ⇒ After the cement concrete is properly set the wall bracket can then be secured to the wall with the help of bolts. It is very important to put the wall bracket only after the cement concrete has set in.

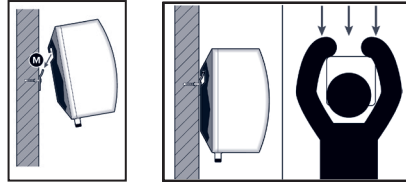
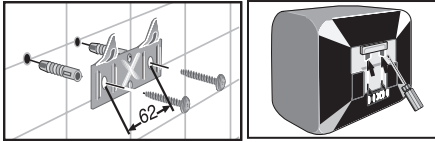

## INSTALLATION:

### Mounting and plumbing

Wall mounting bracket is supplied with the water heater.

2. Mark the position of the bolts on the wall, after checking the same with the mounting bracket supplied with the water heater.
3. Hook the water heater to the mounting bracket fix on wall and pull down the water heater slightly by hand to cause firm gripping in the hook of the bracket.
4. The cold water inlet pipe is circled with a blue collar while the hot water outlet pipe with red collar.
5. Fix ½" BSP union coupling on inlet and outlet connections.
6. Make necessary plumbing with the reference of the installation diagrams shown.

1. Pressure Reducing Valve (PRV)
2. Multi-function safety valve (MFSV)
3. Cold water inlet
4. Hot water inlet
5. Dead Weight Valve (DWV)
6. Stop Clock (SC)

PRV should be installed at a minimum distance of 12 feet from the inlet pipe, to avoid safety valve dripping.

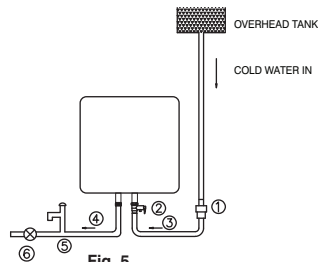

Fig. 5

7. Ensure proper ventilation where the water heater unit is been installed.

As seen in fig.5, a Dead Weight valve can also be fitted at the outlet connection as a double safety measure against positive pressure above the rated pressure (8 Bar) Please ensure that adequate arrangement for piping away the relieved water is made .Dead weight valve is available as an extra option. For servicing, lift the dead weight valve to ensure easy flow of water from the relief tube. This should be done atleast once in a month.

Please ensure that the pressure in the water heater is less than the rated pressure. install pressure reducing valve at the inlet as shown **Fig.5.**

## MAINS CORD :

- 3 Pin Plug, 3 Core × 1.0 Sq. mm (32 ×0.2) PVC Sheathed,16A, 250V with ISI mark certified for Andris 2 Kw products.
- 3 Pin plug, 3 core × 1.5 Sq.mm (48×0.2) pvc sheeted, 16A, 250V with ISI mark certified for Andris slim 2.5 Kw products.

## ELECTRICAL CONNECTION:

Refer wiring diagram, Fig. 6 to Check electrical connection. Ensure proper earthing at 3pin supply point.

## WIRING DIAGRAM:

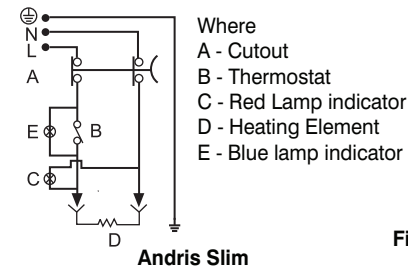

Andris Slim

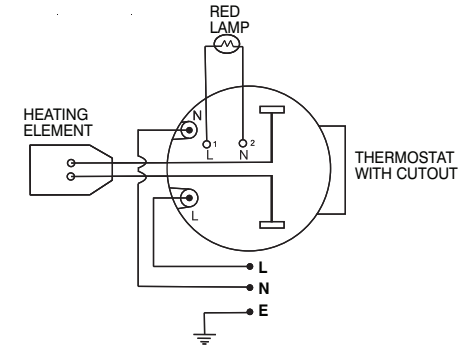

Fig. 6

Andris Uno/R/Lux Plus

**Note:** Main's cord or any other electrical component must be repaired / replaced by authorized service personnel only. Minimum Contract separation of 3mm is required in all disconnection.