

INSTRUCTION MANUAL

Please read this carefully before installation



**ELECTRIC STORAGE
WATER HEATER**



Dear Customer,

Thank you for choosing a world-class product from Ariston Group India Private Limited. Your choice for nothing but the best is reflected by your trust placed in Ariston. Racold is registered trademark of Ariston Spa Italy.

Ariston Group India Private Limited is a fully owned subsidiary of Ariston Spa Italy, and part of the Ariston Group the leaders in water heater.

Today Ariston Group India Private Limited is the largest provider of water heating solutions in India, catering to all sectors water heating namely “Electrical, Gas, Solar and Heat Pump water heaters”.

The Racold range of products from Ariston Group India Private Limited have changed the industry standards by setting new benchmarks in quality, aesthetics and performance.

Our many firsts in India include:

- Water heater with rust proof polypropylene body.
- Stainless steel inner container with multi-function safety valve for high pressure operation without additional pressure reducing valve.
- PUF insulation for maximum energy saving.
- Energy labelling for any domestic electrical appliances.
- Only water heater with quality and performance certification as per IEC/EN and Indian standards (ISI mark).
- Won highest number of National Energy Conservation Award from BEE (Bureau of Energy Efficiency) for electric storage water heaters.

Retain this manual safely and in case you need any assistance you may get in touch with any of our customer care centres, the details of which are enclosed.

Kindly follow the instructions given in this manual and enjoy years of trouble-free performance.

For further information including but not limited to FADs, relevant products please visit our website by scanning this QR code.



PRODUCT FEATURES:

1. High density PUF insulation.
2. Strong non-corrosive and durable PP outer body and inspection cover.
3. Hi-tech thermostat and cut-out, for double safety.
4. Voice Control: Connect your water heater to Alexa or Google Assistant and control it using voice commands. Simply say "Alexa, turn on the geyser".
5. Auto Diagnosis: The microprocessor in the water heater continuously monitors it and cuts off power in case of any malfunctioning, protecting you from shock or any mishap.
6. Auto Power OFF: Schedule your water heater to turn off automatically at a pre-set time for added convenience and energy saving.
7. Quick Heating: Elevate your showers with Quick Heating! The powerful 2.5kW heating element delivers an experience of 3kW output, ensuring faster heating with energy savings.
8. Advanced Titanium: Titanium Plus Enamelled & durable inner container with high pressure withstanding capacity enabling long life & suitable for high rise buildings and pressure pump applications.
9. Racold NET APP: Control your water heater from anywhere, anytime. Turn it On/Off, set the temperature, or schedule it for later. Simply log in to the Racold NET App and enjoy convenience at your fingertips.
10. 4 in 1 Multifunction Safety Valve.
11. Compact size.
12. Drip proof construction. 
13. Special flush mounting.
14. **Flexomix:**

During the use, every withdrawal of hot water from the water heater is then balanced by cold water coming in. The "Flexomix" technology provides better management of the cold water coming inside the water heater. The special flexomix deflector allows the water to mix more slowly, keeping the internal water temperature high and avoiding re-beating of water unnecessarily thereby saving precious electricity. The flexomix system, with its new deflectors of water coming in, allows the user to draw up to 10% more hot water than a traditional water heater of the same capacity.
15. **Silver ION Technology:**

The Ag+ cartridge technology by Racold have the added advantage of an antibacterial capability, and actively stop the proliferation of E-coli, Salmonella,

Legionella, Mould Fungi & more. Silver spheres placed inside the tank in a specially designed cartridge, at the lever of the water net pipe, allowing the water contained in the tank to receive bacteriostatic effect by contact with Ag+ spheres. Available in Omnis Slim Wi-Fi model.

KNOW YOUR WATER HEATER :

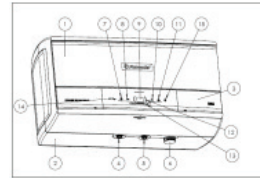

1. Front cover
2. Back Cover
3. Bottom Panel
4. Outlet Pipe
5. Inlet Pipe
6. Anode cap
7. Wi-Fi Button (Enable/Disable Wi-Fi)
8. Set Button (To set Desired Temp or Auto Off Time)
9. Temperature Indicator
10. Product On/OFF Button
11. Auto Power Off button (Enable/Disable Auto Off)
12. Hot water Level Indicator (Blue 4 Segment)
13. Red/Blue Indicator (Red-Heating, Blue - Hot water Ready)
14. Child care for scalding prevention
15. Safety Check: Blinking during product activation & steady when product in use

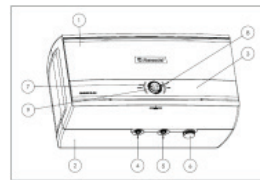

1. Front cover
2. Back Cover
3. Bottom Panel
4. Outlet Pipe
5. Inlet Pipe
6. Anode cap
7. Red Lamp
8. Blue Lamp
9. Knob

IMPORTANT INSTRUCTIONS:

Ariston Group India PV. Lid. cannot be held responsible for the damages caused by wrong Installation, faulty material, using substandard water or for not following instructions included in this Instruction manual, particularly:

1. Installation of the water heater should be done by qualified personnel only.
2. In case the installation is being done on a wall with hollow bricks, refer 'Preparation for Installation' Page 6.
3. Use pressure reducing valve in case rated water pressure is higher than recommended.
4. The electrical connection should be in accordance with the instruction given, refer Page 6.
5. The safety valve supplied with the water heater should be fitted to the inlet connection and should not be disturbed with. For servicing safety valve, refer 'Safety Devices' Page 4.
6. When newly installed, make sure that the water flows freely from the outlet tap (or spout) before electric supply is switched on.
7. Inlet water line should be continuously open when water heater is in use except when it is being serviced.
8. Switch off water heater when not in use to save electricity charges.
9. In case a dead weight safety valve is being used it should be serviced regularly.

1. It is recommended that the IN/OUT pipes and heating element be de-scaled at least once in 6 months.
2. While using the water heater first time, ensure water is dispensed through outlet before switching ON product. Failure to do so will cause damage to heating element.
3. As per safety norms, Thermostat & Cut out are set at desired temperature & it recommended not to change the setting.
4. As per safety norms, Safety Valve is set at desired pressure & it recommended not to change the setting.
5. Optimum performance of the water heater is achieved when the total hardness of water <400 ppm & chloride content <300 ppm.

SAFETY DEVICES:

A. Multi-functional Safety Valve: (Non-Return Valve/Vacuum Release Valve/ Pressure Release Valve / Drain Valve)

Non-return function will not allow the back flow of hot water from inlet. In-built multifunction safety valve (Pressure relief valve) is set to operate between 7.5 bar (109 p.s.i.) and 8.5 bar (123 p.s.i.). Vacuum relief valve prevents the formation of vacuum inside the container. Drain lever (L) is provided to drain the water heater only in case of servicing. Check for any leakage before switching on electric supply. In case of safety-valve dripping during normal use, connect a discharge pipe (P) (as shown) for piping away the relieved water. In a continuously downward direction and in a frost-free environment. **In case copper Pipe plumbing is done, additional 1/2-inch connector or adaptor to be connected to avoid safety valve damage by copper pipe.** Contact nearest service centre for discharge pipe availability. To avoid deposition of limes in the safety valve, please move the lever (L) up & down few times. This should be done at least once in a month. Minimum water head of 50cms. is required at inlet for water to enter inside the container.

The safety valve (A) should be serviced at least once a month. Before servicing the safety valve, ensure that the water heater is switched off and water inside is not hot. Connect the discharge pipe (P) in a downward sloping position to the safety valve at the discharge hole provided. The water may drip from the discharge pipe of the pressure relief device and that this pipe must be left open to the atmosphere. A discharge pipe connected

to the pressure-relief device is to be installed in a continuously downward direction and in a frost-free environment."

B. Thermostat:

Hi-tech adjustable thermostat with automatic ON-OFF indication on display of control panel and variable setting of temperature. The temperature of water at which the thermostat in event of failure will cut off can be adjusted by setting the control panel to the desired temperature. This should be kept as low as possible, consistent with hot water demand. Scale formation in water heaters can be limited if due care is given to the temperature. The thermostat can be withdrawn without having to drain the water and in the installed position.

C. Thermal Cut-out:

Hi-tech thermal cut-out non-self-resetting type set to disconnect electrical supply through two poles for extra safety. Please contact qualified service personnel in such an event.

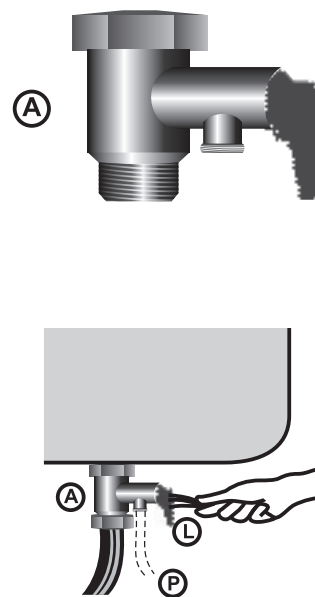

Fig. 2

Note: The rated pressure is developed inside the tank after heating at outlet pipe. It is recommended to maintain approximately 1.5 bar pressure at inlet pipe.

HEATING ELEMENT:

Self cleaning heating element: Omnis Slim

The heating element is made of best anti-corrosive material & guarantees absolute isolation between electricity & water.

Racold's self-cleaning Heating Element made of a special stainless-steel alloy that has a

specially treated surface (brightened) The self-cleaning Heating Element has proved to be an extra help for **low energy consumption** & for a **longer life of the inner tank**. Thanks to its smooth & bright surface. the lime stone does not lay on the heating element thus allowing the heat to be efficiently exchanged with the water, **even after long period use**.

Advanced Titanium: Titanium Plus Enamelled & durable inner container with high pressure withstanding capacity enabling long life & suitable for high rise buildings and pressure pump applications.

OPERATION INSTRUCTIONS:

1. Switch on the water heater's main supply, red indicator lamp comes on.
2. The red indicator lamp switches off indicates water inside the water heater reached to the set temperature.

MODEL	A	B	C	D	E	F	G	H	I	J
OMNIS SLIM 15L	590	316	326	87	187	240	163	217	100	159
OMNIS SLIM 25L	678	358	365	108	189.5	326	162.5	303	100	179
OMNIS SLIM WIFI 25L	678	358	358	108	189.5	326	162.5	303	100	179

PREPARATION FOR INSTALLATION:

1. For the installation of this water heater you need to prepare the wall suitably and more so if the wall is constructed out of hollow bricks.
2. For solid bricks the usual method of installation of drilling holes in the wall and securing bolts in the right position with the help of cement concrete can be adopted, use M8 x 75 mm bolts.
3. However, for hollow bricks the following procedure should be adopted:
 - ⇒ Dig up sufficient space to accommodate the wall mounting bracket supplied with this water heater, up to a minimum depth of 80mm and fill up the complete space with Cement concrete.
 - ⇒ After the cement concrete is properly set the wall bracket can then be secured to the wall with the help of bolts. It is very important to put the wall bracket only after the cement concrete has set in.

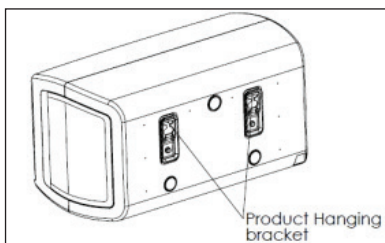

SPECIFICATIONS:

Model	OMNIS SLIM	
Capacity declared (Ltrs)	15L	25L
Real capacity (Ltrs)	15.4	25.6
Power supply	230V, 50Hz, Single Phase	
Wattage (Kw)	2.5	2.5
Reheatin Time for 50 temp rise (minutes) Max	35	50
Mean Hot water output temp (Min)	50	50
Mixing factor (Max%)	30	30

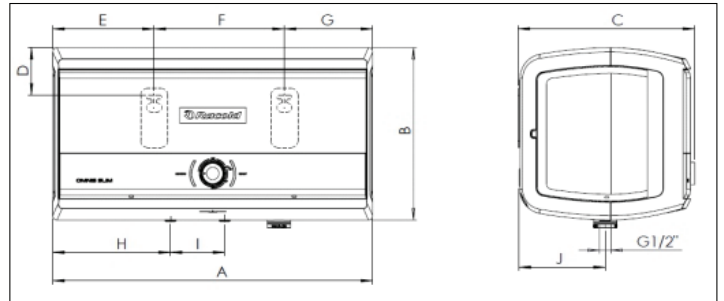

Maximum rated pressure -

8.0 Bar/800000 Pascal/0.80 MPa/80N/cm²
/-80m Water Head.

Minimum inlet water pressure -

5000. Pascal (0.05 bar) for all models.

IP rating - IP 24 for all models.

NOTE:

a) All dimensions are in 'mm'.

b) "E" represent the distance between top of product to mounting positions (back side).

INSTALLATION:

Mounting and Plumbing

1. Wall mounting bracket is supplied with the water heater.
2. Mark the position of the bolts on the wall, after checking the same with the mounting bracket supplied with the water heater.
3. Hook the water heater to the mounting bracket fix on wall and pull down the water heater slightly by hand to cause firm gripping in the hook of the bracket.
4. The cold-water inlet pipe is circled with a blue collar while the hot water outlet pipe with red collar.
5. Fix 1/2" BSP union coupling on inlet and outlet connections.
6. Make necessary plumbing with the reference of the installation diagrams shown.
7. Ensure proper ventilation where the water heater unit is been installed.
8. In case of water dripping from safety valve, please put drain pipe (as shown in Fig.2).
9. Product must be installed in a such a way that it should be easily accessible for servicing.
10. The mounting of the dielectric joints as per figure is mandatory. Please mount them before safety valve.

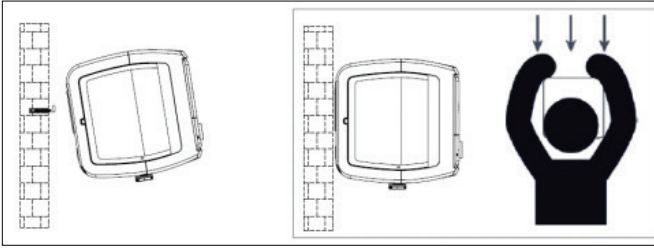

As seen in Fig. 5, a Dead Weight Valve can also be fitted at the outlet connection as a double safety measure against positive pressure above the rated pressure (8 Bar) Please ensure that adequate arrangement for piping away the relieved water is made. Dead weight valve is available as an extra option. For servicing, lift the dead weight valve to ensure easy flow of water from the relief tube. This should be done at least once in a month.

Please ensure that the pressure in the water heater is less than the rated pressure. Install pressure reducing valve at the inlet as shown in Fig. 5.

PRV should be installed at a minimum distance of 12 feet from the inlet pipe, to avoid safety valve dripping

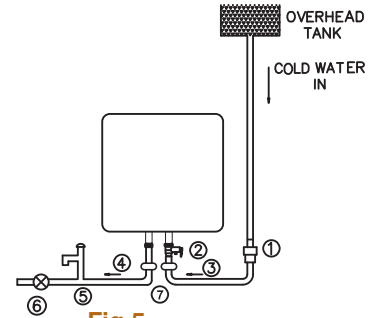

Fig.5

1. Pressure Reducing Valve (PRV)
2. Multi-function safety valve (MFSV)
3. Cold water Inlet
4. Hot water outlet
5. Dead Weight Valve (DWW)
6. Stop Cock (SC)
7. Die Electric joint

MAINS CORDS:

- 3 Pin Plug, 3 Core x 1.5 Sq. mm (48 x 0.2) PVC Sheathed, 16A, 250V with IS mark certified for Omnis Slim 2.5kW Products.

Note: Main's cord or any other electrical component must be repaired / replaced by authorized service personnel only. Minimum contact separation of 3mm is required in all poles for disconnection.

WIRING DIAGRAM:

OMNIS SLIM WiFi

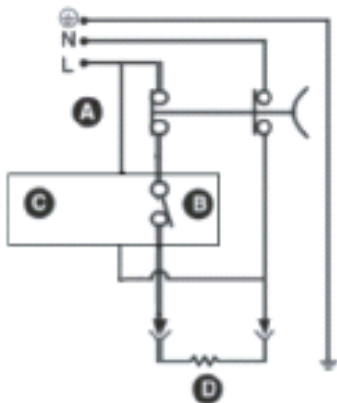

OMNIS SLIM

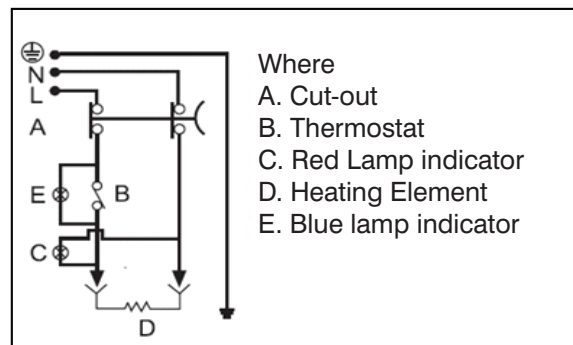

TROUBLE SHOOTING GUIDE FOR WATER HEATER

#	Problem / Observation	Possible Causes	Solution / Remarks
1	Water Heating takes longer time than specified in instruction manual.	Scaling on the Heating Element cause slower water heating.	Get the Heating element de-scaled from authorised service person or replace with genuine spare parts recommended by company. Measure the temperature of water using thermometer. Adjust the flow rate at 3 Ltrs/min.
		Low voltage at certain places.	Check the voltage at customer's place.
2	Equipment creates abnormal noise.	High voltage fluctuations, hard water.	Recommend Spare HE with low watt density (8W/cm ²).
	Equipment creates hissing noise.	Due to scaling on HE.	Descaling HE.
3	Unit not working.	Power point may not be working.	Need the line at customer's place to be checked.
		Check for any short circuit of harness/power cord inside.	
		Cut out operated due to dry heating	Reset Cut out
		Heating Element might not be functioning may be due to Dry heat or short/Crack/burst heavy scaling).	Replace HE.
4	Leakage of the unit.	Rusting of the tank.	Check from where the leakage is (tank, collar, gasket, HP), Replace or repair based on the observation.
		Not enough torque to the bolts on HP / HE flange.	Replace or repair based on the observation.
		Leaking from HE Brass flange (instant WH).	Replace HE.
5	No Hot water output.	HE not working.	Reset Cut out.
		Thermostat low setting (check if someone tampered the setting in instant water heater).	
		Cut out trip.	
		Inlet valve closed.	Open the inlet valve.
6	User gets mild shock when using WH.	Improper earthing at customer's place.	Check for proper earthing & if not then suggest customer to do it properly.
7	Outlet water blockage.	Heavy scaling on Outlet pipe opening end.	Descaling the product from authorised service personnel.
8	Leaking from MFSV (Safety Valve).	Excess pressure than rated pressure.	Check the ensure nethie ists in ON. Note: When MFSV is dripping, it ensures safety of the equipment from excess pressure. Put drain pipe at MFSV with clip.
		Check NRV position from inlet pipe.	It should be minimum 12 feet from equipment.
			Check if PRV is there in high rise building
9	Water Heater unit burnt.	Short circuit of the harness / power cord.	Replace harness asm or power cord.
		Use of Low Amp power cord.	
10	Smell comes out of water.	If Water heater unit is not used in 15- days water inside smells for some time.	Flush out 2 times capacity of water heater.
11	If the Red LEDs go OFF and also the Blue LEDs are off (No lights).	Thermal cut-out is activated	Then contact the service personnel.

DOs AND DON'Ts OF WATER HEATER

#	DOs	Remarks
1	Installation of water heater should be done by qualified person only preferably from Racold service.	Product warranty will get void in case of wrong installation.
2	Use pressure reducing valve in case rated water is higher than recommended.	To Avoid Water dripping from safety valve.
3	Inlet water line should be continuously Open when water heater is in use except when it is being serviced.	
4	Ensure proper levelling of the unit while doing installation.	If tilted, it may affect the hot water output quantity.
5	Ensure proper earthing at the place of installation.	Chances of getting shock.
6	Use ISI marked or branded company power plugs only.	Use 16 Amp power plug only.
7	Use of two spanners suggested while installing the product (connecting the hose pipes).	There may be a chance of crack on the pipes if we don't do so.
8	Ensure water coming out from outlet prior switching the unit ON (first time).	If no water inside tank, unit goes into dry heat causing damages, burning etc.
9	Its mandatory descales IN/OUT pipes, heating element and safety valve at least once in 6 months when water hardness is greater than 400 ppm if lower (1) this type of maintenance is recommended Operation must be done only by Racold authorized Service (Intervention charge shall be applicable).	This helps in Improving product life
10	As per the safety norms Thermostat, cut out are set at desired temperatures and Safety Valve set at desired pressure and its recommended not to change the settings.	Product warranty will get void if setting changed.
11	Power OFF the unit while servicing the water heater unit.	Chances of product burning/Safety purpose.
12	Use only genuine company spare parts from authorised service centres.	Product warranty will get void if used other than company recommended spare parts.
#	DON'Ts	
1	Use connectors in case it is required to connect another cord with main power cord came along with the product.	Chances of product burning/Safety purpose.
2	Do not tamper the thermostat setting.	As per safety standards, thermostats are set at desired temperatures. Recommend not to change the settings.
3	Do not switch ON the product without checking the water coming out from outlet.	Chances of product burning.
4	Do not adjust / disturb Safety valve setting.	As per safety standards. Safety valve are set at desired pressure. Recommend not to change the settings.

IMPORTANT NOTES:

- Optimum performance of the water heater is achieved when the total hardness of water <400 pm & chlorides content < 300 ppm.
- In case a pressure reducing valve (or non-return valve) is used in installation, please ensure that it is installed at a minimum distance of 12 ft. from the inlet point.
- Please ensure the installation of water heater to be done by keeping minimum 1 foot from the wall on either side.
- Anode should be checked periodically within 6 months. If the anode goes below 7mm diameter, replace it by authorized service personnel on at chargeable basis.
- In case of product installed at inaccessible place, it is responsibility of customer to dismount the product and make it available to the service representative.
- AMC - It is recommended to take AMC and extended warranty from authorized service franchisee.
- Visit charges shall be applicable for product Installation, Demonstration & explanation related calls.
- Please ensure proper ventilation whenever the unit is installed to avoid any rust formation/aggravation.

Electric Water Heater Installation Guidelines for Plumbers

- Read Instruction Manual carefully and follow installation instructions.
- Safety valves are pre-set for certain working pressure. Under any circumstances do not tamper / over-tighten the safety valve.
- Continuous water dripping from Safety valve is an indication of excessive pressure at inlet of water heater compared to the rated pressure. In that case install pressure reducing valve at the inlet.
- Check for leakages after installation, plumbing & before switching ON the power supply.
- Ensure flow of water from outlet before connecting electric power supply to the appliance.
- Do not use excessive force while tightening Inlet and outlet couplings. This may cause serious damage to the Water Heater. Use cross spanner for tightening.
- Check supply voltage at the place of installation 230V.
- Ensure proper earthing of electrical connection.
- No extension cords to be used.
- Use only ISI marked electrical accessories of proper rating e.g. 3 pin plug, connection boxes, wires etc.
- In Storage water Heaters, check whether red lamp is glowing when the water heater. is switched on. Blue light is glowing, when hot water ready in Omnis Slim.
- Ensure all Couplings / Joints are leak-proof.
- Check the Water Heater operation for one complete cycle i.g. one cycle of Thermostat operation, i.e. Cut-off and cut-in.

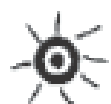
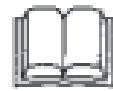

Blue

Red





LED & Buttons	Functionalities
1- On/Off Function	Press to Switch ON or OFF the Product
2- Set button	Press to Regulate the desired temperature from 40°C to 80°C, also to select desired timing of Power Off function (15, 30, 60, 90 minutes).
3 - Auto Power off	Press to activate/Deactivate the function. Note: Check the specific paragraph of this manual to operate with this
4- Wi-Fi button	Press to activate/deactivate Wi-Fi. Press for 5 sec. to activate Access Point (to connect to router Wi-Fi) Note: check the specific paragraph of this manual to operate with Wi-Fi
5- Child Care	When Temperature of water inside tank is reach up to 45°C, Child care symbol will blink steady in Blue colour. Once temperature goes beyond 45°C, Child care symbol will get blink off.
6- Safety Check	Safety Check: Blinking during product activation & steady when product in use
7- Red/Blue LED	Red/Blue Indicator (Red-Heating, Blue - Hot water Ready)
8- Digit Display	The Display shows normally the internal average temperature of the hot water. During the regulation of the temperature the display shows the set point temperature. During the Auto Power Off activation the display shows the available timer options.
9- Hot Water level ready	Hot water ready (full product) - 4 segments, not blinking

SWITCH-ON THE PRODUCT

Every time the product is powered by the external switch or the main cord, the appliance performs a self-check and all LED's are switched ON and the display shows the text "nF" for 1sec. to verify the loading of NFC parameters.

TEMPERATURE SETTING

The temperature can be regulated by the button [SET].

Press the [SET] button several times or keep it pressed until the required temperature is showed on the display.

Once finished, the display will show again the average internal temperature of the water

ANTIBACTERIAL FUNCTION

The product runs automatically a self-cleaning cycle at 65°C of temperature, for 1 hour, to prevent the formation of bacterial inside the tank in case the water heater is not used for a long time.

The cycle will be executed only if the selected temperature is below 60°C.

If the function is activated, the cycle will run each time the product is powered (by main switch) and it is repeated every 30 days. This function is disabled by default, can be enabled by pressing together buttons (SET) & (ON-OFF) for 3 sec. The display will show momentarily "Al". To disable press again, together, the buttons [SET] & [ON-OFF) for 3 sec. The display will show momentarily "AO" When anti-bacterial cycle is in progress the display shows "Ab".

ANTI-FREEZE FUNCTION:

The Antifreeze function prevents ice formation inside the tank. If water temperature goes below 5 °C, the heating element will be switched on until a protection value is reached. When antifreeze protection is in progress the display shows "AF*".

ECO FUNCTION:

The Eco function aims to produce hot water by learning the user habits. For the first week ever the product memorizes the water withdrawals and the periods in which those withdrawals take place. From the following week the water heating is performed based on what learned previously. If the user wants to reset the function and start a new learning period, it is necessary to reset the function, as explained below.

If temperature is modified or Weekly Program Mode is selected (for WI-FI products) the Eco function is automatically disabled.

The function is disabled by default.

Standard version: The function can be

enabled/disabled by the APP or can be activated by the user interface pressing together buttons [SET] & [Auto Power Off] for 3 sec. The display will show momentarily "Eo" if the function has been disabled or "E1" if enabled.

Wi-Fi version: The function can be enabled/-disabled by the APP or can be activated by the user interface pressing together buttons [SET] & [WIF] for 3 sec. The display will show momentarily "EO" if the function has been disabled or "EI" if enabled.

All data stored by the ECO function are lost after 2 hours without power supply or can be erased manually.

Standard version: pressing together buttons (SET) & (Auto Power Off) for 5 sec. The display will show momentarily "E-" to confirm the data has been cancelled.

Wi-Fi version: pressing together buttons (SET) & (WIFI) for 5 sec. The display will show momentarily "E-" to confirm the data has been cancelled.

QUICK HEATING:

Heating element designed for Omnis Slim Wi-Fi in such a way that heating time to reach the target temperature is 15-20% shorter than Omnis slim RS Heating element.

WEEKLY PROGRAM FUNCTION

The weekly program function can be activated only via APP. There is no feedback on the HMI that this mode has been selected. The user can select for each day of the week two different set point temperatures at two different times. If the set point temperature is modified, ECO function or Auto Power Off is selected the WEEKLY PROGRAM will be deactivated.

NEW AUTO POWER OFF FUNCTION

With the new function the product automatically turns off after a pre-selected timing by the user:

Press the button [Auto Power Off] to activate the function - Blu light and display will blink during this step.

Press the button [SET] to select desired timing of deactivation (15, 30, 60, 90 minutes). 30 minutes is the default timer for first time setting - Blu light and display will blink during this step

To exit the "set mode" wait for time out (5 seconds) - Count down will start after the set point temperature is reached. During the selected timing the product keep the temperature of the water at the selected set point before switching off. To disable the function, press the button [Auto Power Off] at any time.

After product switches off automatically:

Press [On-Off] button to reactivate the product and the Auto Power Off function will be on again with the last setting.

Press the main switch (on the wall) OFF and ON again for at least 3sec. The product will turn on (heating on), with Auto Power Off function activated, with last timer setting.

Error/Auto Diagnosis

In case of error the display shows automatically the text "Er" and alternately the error code as shown in the table below. At the same time all LED's blinks to indicate the error status

ERROR CODE	ERROR	FOR USER	FOR TECHNICAL ASSISTANCE (check power cable and internal connection)
E01	HMI MEMORY ERROR	Perform reset. If the error is still present call the technical assistance.	Perform reset. If the error is still present, change HMI board.
E21	OVERHEATING		Wait until the temperature of water is less to 75°C and perform reset. If the error is still present, check the connections. Wait until the temperature of water is less to 75°C and perform reset. If the error is still present, change temperature probe. Wait until the temperature of water is less to 75°C and perform reset. If the error is still present, change the HMI board. Wait until the temperature of water is less to 75°C, and perform reset. If the error is still present, change the thermostat board. Wait until the temperature of water is less to 75°C, and perform reset.
E22	THERMOSTAT ERROR		Wait until the temperature of water is less to 75°C and perform reset. If the error is still present, change the thermostat board. If the error is still present, change the HMI board.
E25	DRY HEATING	Check the presence of water and perform reset. If the error is still present call the technical assistance	Check the presence of water and wait until the temperature of water is less to 75°C and perform reset. If the error is still present, change temperature probe. If the error is still present, change HMI board. If the error is still present, change thermostat board.
E20	TEMPERATURE SENSOR ERROR	If the error is present call the technical assistance.	Check the connections. If the error is still present, change temperature probe. If the error is still present, change HMI board.
E62	HMI MEMORY DATA ERROR		Try to reprogramming NFC and perform reset with disconnect and reconnect the power supply cable If the error is still present, change HMI board
E60	WIFI ERROR	Perform reset with disconnect and reconnect the power supply cable. If the error is present call the technical assistance	Perform reset with disconnect and reconnect the power supply cable. If the error is still present, change HMI board
E61	HMI PCB ERROR		Perform reset with disconnect and reconnect the power supply cable. If the error is still present, change HMI board
E63	TOUCH ERROR		Perform reset with disconnect and reconnect the power supply cable. If the error is still present, change HMI board

PRECAUTIONS

1. In order to avoid a hazard due to inadvertent resetting of the thermal cut-out, this appliance must not be supplied through an external switching device, such as a timer, or connected to a circuit that is regularly switched on and off by the utility.
2. In case a pressure reducing valve (or a non-return valve) is used in the installation, please ensure that it is installed at a minimum distance of 12 feet from the inlet point. Installing the PRV (or NRV) without respecting this minimum distance may cause safety valve dripping.
3. The new hose-sets to be used and that old hose-set should not be reused.
4. This appliance can be used by children aged from 8 years and above and persons with reduced physical, sensory or mental capabilities or lack of experience and knowledge if they have been given supervision or instruction concerning use of the appliance in a safe way and understand the hazards involved. Children shall not play with the appliance. Cleaning and user maintenance shall not be made by children without supervision.
5. If the supply cord is damaged, it must be replaced by a special cord or assembly available from manufacturer or its service agent having same electrical rating and specification.
6. Please use a 3-pin plug of 16A rating for electric connection & ensure secure connection of the earthing wire.
7. Please ensure to mount the water heater keeping sufficient space on the left-hand side (~350-400 mm).
8. This will facilitate easy servicing product without dismounting.
9. Maintenance
10. The anode should be checked within 12-18 months from the installation. If the diameter goes below 7 mm, it should be replaced with a new anode (this operation should be performed by authorised personnel).

IMPORTANT

This warranty is valid subject to installation of the unit as per the instruction manual and the conditions stated there in. This warranty will not apply to any Racold Water Heater which has been tampered with or altered in any way or which has been subjected to misuse, negligence or accident.

For water heaters installed at inaccessible places such as above a false ceiling, inside a duct etc. It is the responsibility of the customer to dismount the product and make it available to the service representative.

Its recommended to take AMC & Extended warranty from Racold's authorized service franchisee.

We recommend to use genuine Racold spare parts only.

Visit charges shall be applicable for product installation, demonstration & explanation related calls.

WARNING MARKING

The instructions shall include a warning that the appliance shall be disconnected from its power source during service and when replacing parts and, if that the removal of the plug is foreseen, it shall be clearly indicated that the removal of the plug has to be such that an operator can check from any of the points to which he has access that the plug remains removed."

CAUTION MARKING

In order to avoid a hazard due to inadvertent resetting of the thermal cut-out, this appliance must not be supplied through an external switching device, such as a timer, or connected to a circuit that is regularly switched on and off by the utility."

Correct Disposal of this product

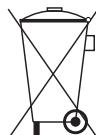

This marking Indicated that this product should not be disposed with other household wastes throughout the EU. to prevent possible harm to the environment or human health from uncontrolled waste disposal, recycle it responsibly to promote the sustainable reuse of material resources. To return your used device, please use the return and collection systems or contact the retailer where the product was purchased. They can take this product for environmentally safe recycling.

WARRANTY CARD



PLEASE COMPLETE THE FOLLOWING DETAILS:

Product: ELECTRIC STORAGE WATER HEATER

Model No: _____ Serial No: _____

PURCHASER'S NAME & ADDRESS: _____

DEALER'S NAME & ADDRESS: _____

DEALER'S SIGNATURE: _____

CASH MEMO NO: _____

DATE OF PURCHASE: _____

The Racold water heater comes with warranty for a period of 2 years from the date of purchase against electrical or mechanical failure caused through defective material and workmanship. The inner container warranty against leakage is 7 years for OMNIS Slim Wi-Fi & OMNIS Slim models. The Heating element warranty is 7 years for OMNIS Slim Wi-Fi & 4 years for OMNIS Slim model. In event of failure covered by this warranty, you are requested to contact our customer care & obtain the complaint number. Our trained technicians will repair the product at our discretion. No further liability for the consequential or damage is accepted or implied. We will not be responsible for any human injury, property damages, consequential damages caused due to improper use. All disputes will be subject to Pune Jurisdiction only. The warranty on the inner container includes only the inner container and does not include any other part/s inside or outside of the inner container.

Warranty on the tank and heating element applies only if:

- 1) Annual check of anode is done mandatorily and its replacement done in case of consumption (rod diameter less than 7 mm)
- 2) Warranty will be no more valid in case the maintenance of anode is not done as per point no 1

Following things shall not be covered under warranty:

- 1) Any plumbing and/or Electrical related problems, not related to product.
- 2) Any defects arising due to wrong and/or non recommended installation procedure.
- 3) Dry heating of water heater.
- 4) Consumables such as anode.
- 5) Any human injury, property damages and consequential damages caused due to improper use.
- 6) Tank Cleaning and De-Scaling of the product is chargeable.



It is recommended to install the product through the authorized service centre.

Additional Note: To prevent issues related to CPVC/UPVC, please ensure to verify the suitability of CPVC/UPVC plumbing for water heater installation. Use only if deemed appropriate after confirming compatibility.

Ariston Group India Private Limited

1st Floor, Office No. 103, Mayfair Tower, Wakdewadi, Shivajinagar Pune - 411005, Maharashtra, India.

Customer care number (9 am to 9 pm):

020 6734 2288, +91 8600 25 6000 | 7362 888 999 24x7 | Email: customer.care@racold.com

racold.com

HOT WATER COMFORT, JUST THE WAY YOU LIKE IT.



QUICK START:

1. Connect the safety valve at the inlet of water heater if supplied separately. Don't install water heater without safety valve.
2. Hook the water heater on wall with the help of mounting brackets. Take Necessary dimensions for making holes for mounting brackets.
3. Connect the inlet & outlet piping as marked on water heater.
4. Start water flow inside Water heater & fill it completely till water comes out from outlet connection.
5. Connect the electrical cord to power point.
6. Switch on the water heater's main supply, red indicator lamp comes on.
7. The red indicator lamp switches off indicates water inside the water heater reached to the set temperature.
8. Run a complete cycle of Thermostat ON to Thermostat cut OFF, in presence of service provider / Installation technician / plumber.

Racold Your comfort your way



Winner of
Good Design
Award

MARKETED BY: ARISTON GROUP INDIA PRIVATE LIMITED
1st Floor, Office No. 103, Mayfair Tower, Wakdewadi,
Shivajinagar, Pune-411005 Maharashtra, India.



Customer Care:

Email: customer.care@racold.com



24x7
WhatsApp
Chat Assistance

 73628 88999

 020 67342288
 08600256000

Address: Same as marketed by.
racold.com